

GWS-40 遙控電動模型飛機

R/C ELECTRIC MODEL AIRCRAFT

GWS

www.gws.com.tw
www.gwsus.com



GWS-40

INSTRUCTION MANUAL

Please read this manual thoroughly before Starting to assemble the kit. After reading this manual, please keep it for future reference. This is a kit for Intermediate and Advanced flyers. Appropriate RC flying knowledge & skill is required.



WARNING! This is a hobby kit. Not a toy for children. Strick adult supervision is required for children to use it.

ENGLISH En

中文(繁體) Ct

Specifications/Parts	2
Wing Assembly	3
Landing Gear Assembly	4
Fuselage Assembly	4
Stabilizer Assembly	5
Canopy Assembly	7
Power System Assembly	7
Control System Assembly	8
Control Throw & C.G.	10
RC system & wiring	11
Decals	12
Parts List	15

CE  
PYINS-1132 — V7.1

Manufactured by Grand Wing System China, Inc.

SPECIFICATIONS

Wing Span : 39.4in.(1000mm)	Wing Loading : 12.1~14oz./sq.ft.(36.9~42.6g/dm ²)
Wing Area : 272.8sq.in.(17.6dm ²)	Servo : NARO×4
Length : 33.1in.(841mm)	Receiver : GWS-R6N II / R8M / R8MSL
Flying Weight : 23~26.5oz.(650~750g)	Radio Required : 4CH or Above

GWS-40 Suggested Power System

Power System *	Propeller*	Speed Controller**	Battery Required **	Power Extension Wire*
EPS400C-FS	EP1147	ICS400	9.6V 1100mAh Ni-MH	—————
EPS2028-BS	EP1060HD HD1060X3	ESC25A	11.1V 1300~2200mAh Li-Po(>15C)	3 wires
GWS-BL2215/12T				
GWS-BL3008/16T		ESC35A		

* * for the version with power system, not for NPS or SG version ** Not included

PARTS LIST

01. GWS40 Wing(L)	x2	19. Elevator Stiffner 1.6*100*25mm	x1	37. Press-On stud B	x6
02. GWS40 Wing(R)	x1	20. Tubing (Elevator) 3*2*220mm	x1	38. Hinge Material	x1
03. GWS40 Fuselage(L)	x1	21. Tubing (Rudder) 3*2*180mm	x1	39. Double Sided Foam Tape	x4
04. GWS40 Fuselage(R)	x1	22. V Shape Connecting Rod 2.5*80*165mm	x1	40. Screws M3*35mm	x3
05. GWS40 Vertical Stabilizer	x1	23. Front Wheel ∅2 in	x2	41. Hex Nut M3*5.5*1.8mm	x3
06. GWS40 Horizontal Stabilizer	x1	24. Main Landing Gear(L) 2*105*19mm *	x1	42. Wooden Stick 10*10*120mm	x1
07. GWS40 Landing Gear Seat(L)	x1	25. Main Landing Gear(R) 2*105*19mm *	x1	43. Washer 3mm	x1
08. GWS40 Landing Gear Seat(R)	x1	26. Rear Wheel ∅1 in	x1	44. Rubber Spinner	x1
09. GWS40 Landing Gear Cover(L)	x1	27. Tail Landing Gear 1.2*46*11mm *	x1	45. GWS Glue (24g)	x1
10. GWS40 Landing Gear Cover(R)	x1	28. Tubing 3*2*30mm *	x1	46. 30g Clay Stick	x1
11. Foam Spinner	x2	29. Tubing 3*1.2*20mm *	x1	47. Frame A	x1
12. GWS40 Battery Cover	x1	30. Screws M2*10mm *	x6	48. Frame C	x1
13. GWS40 Canopy	x1	31. Y Split Servo Wire W26/24+6	x1	49. Pushrod Fast Connector 1.5	x4
14. GWS40 Engine Cowling	x1	32. U Shape Plastic Latch A	x1	50. Clear Tubing 5*2*3mm	x8
15. Wing Fiberglass Rod 4*2.5*420mm	x2	33. U Shape Plastic Latch B	x1	51. Washer 2.2*5*0.5mm	x8
16. Stabilizer Fiberglass Rod 3*1.6*300mm	x1	34. Pushrod Snap-on Link ∅1.0	x2	52. Screws M3*4mm	x4
17. Tubing 1*370mm	x2	35. Pushrod Snap-on Link ∅1.4	x2	53. GWS40 Decal Sheet	x1
18. Aileron Tubing 1.4*65mm	x2	36. Press-On stud A	x6	54. GWS40 Instruction Manual	x1

* * Not included in SG kit

Required tools before assembly.

TOOLS & MATERIALS



1. Wing Assembly

1.1. Cut aileron as shown

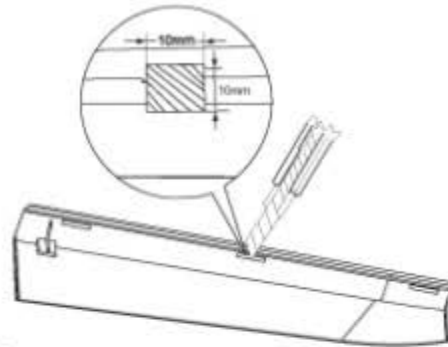
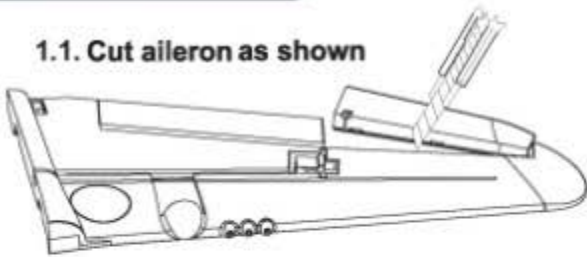

1.2. Cut hinge slots

1.3. Apply GWS glue to each hinge and insert into slots on aileron/wing

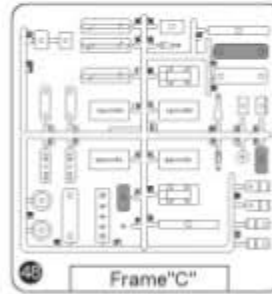

1.4. Bond wings together

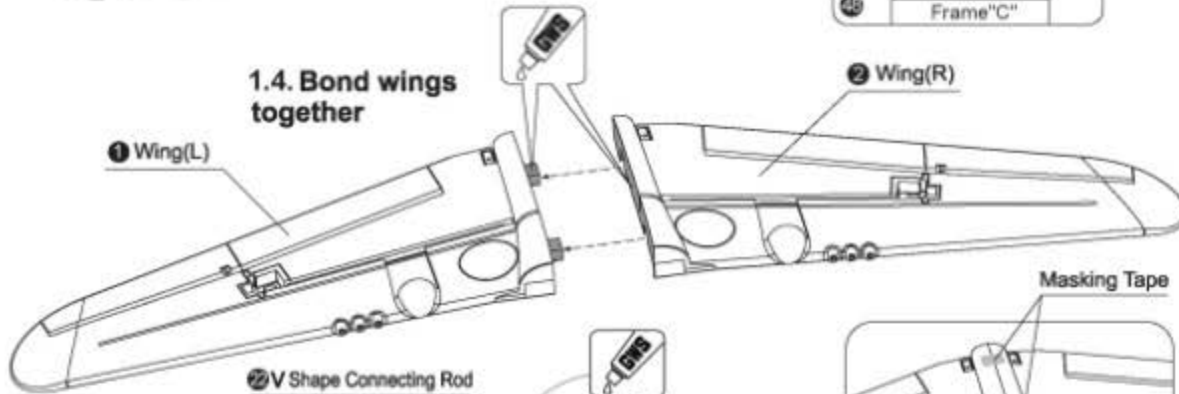

② V Shape Connecting Rod

1.6. Connect/glue fiberglass rods

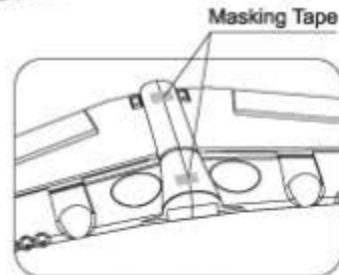
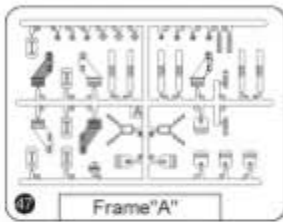

1.5. Secure with tape temporarily

1.7. Secure rods with glue

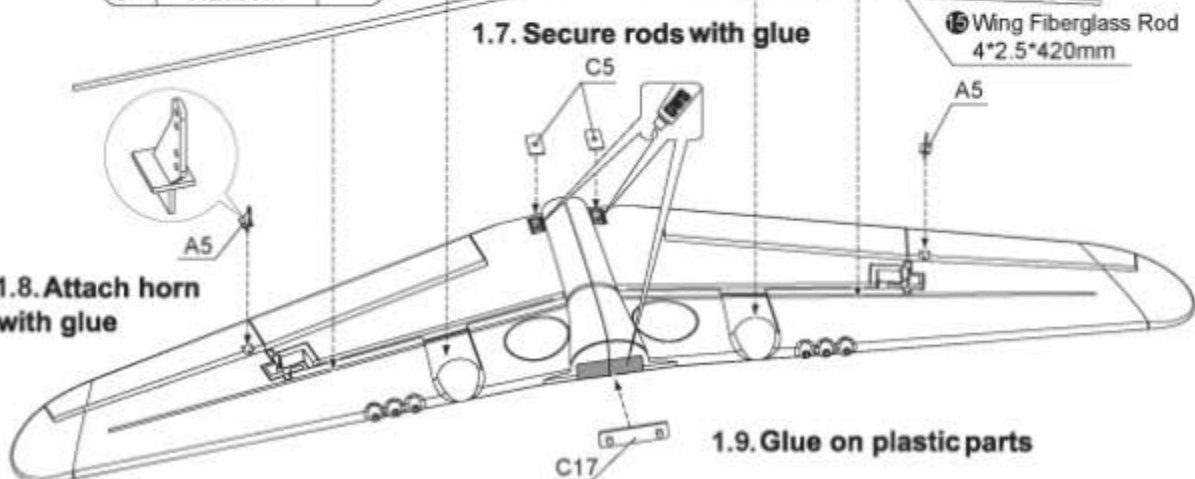

⑤ Wing Fiberglass Rod 4*2.5*420mm

A5

A5

C17

1.9. Glue on plastic parts

1.8. Attach horn with glue

En

2. Landing Gear Assembly

2.1. Cut tubing as shown

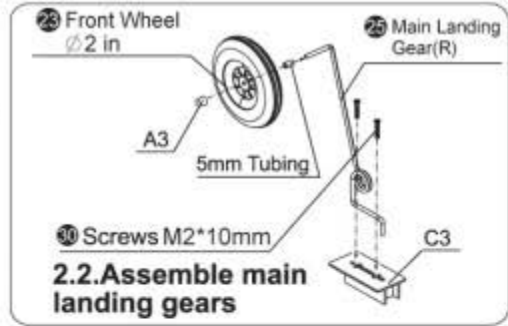
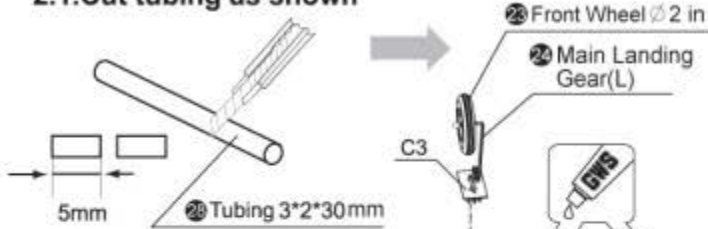

2.3. Glue on main landing gear

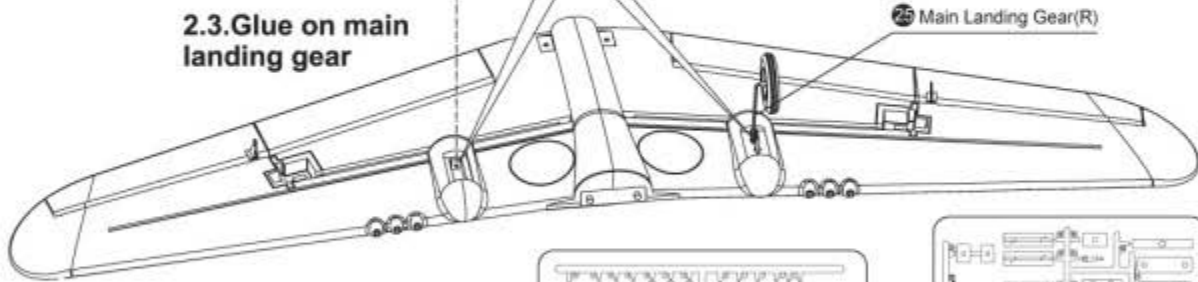

3. Fuselage Assembly

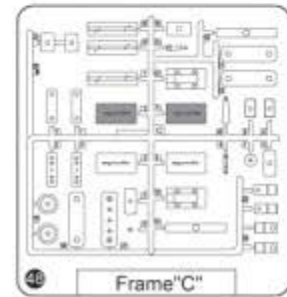
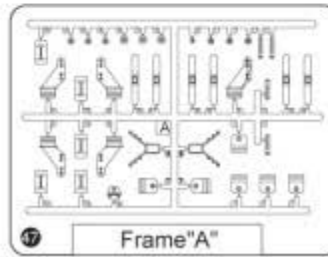

En

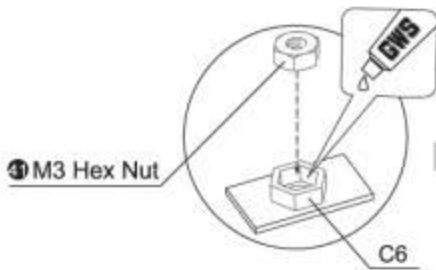

3.1. Glue on hex nut as shown

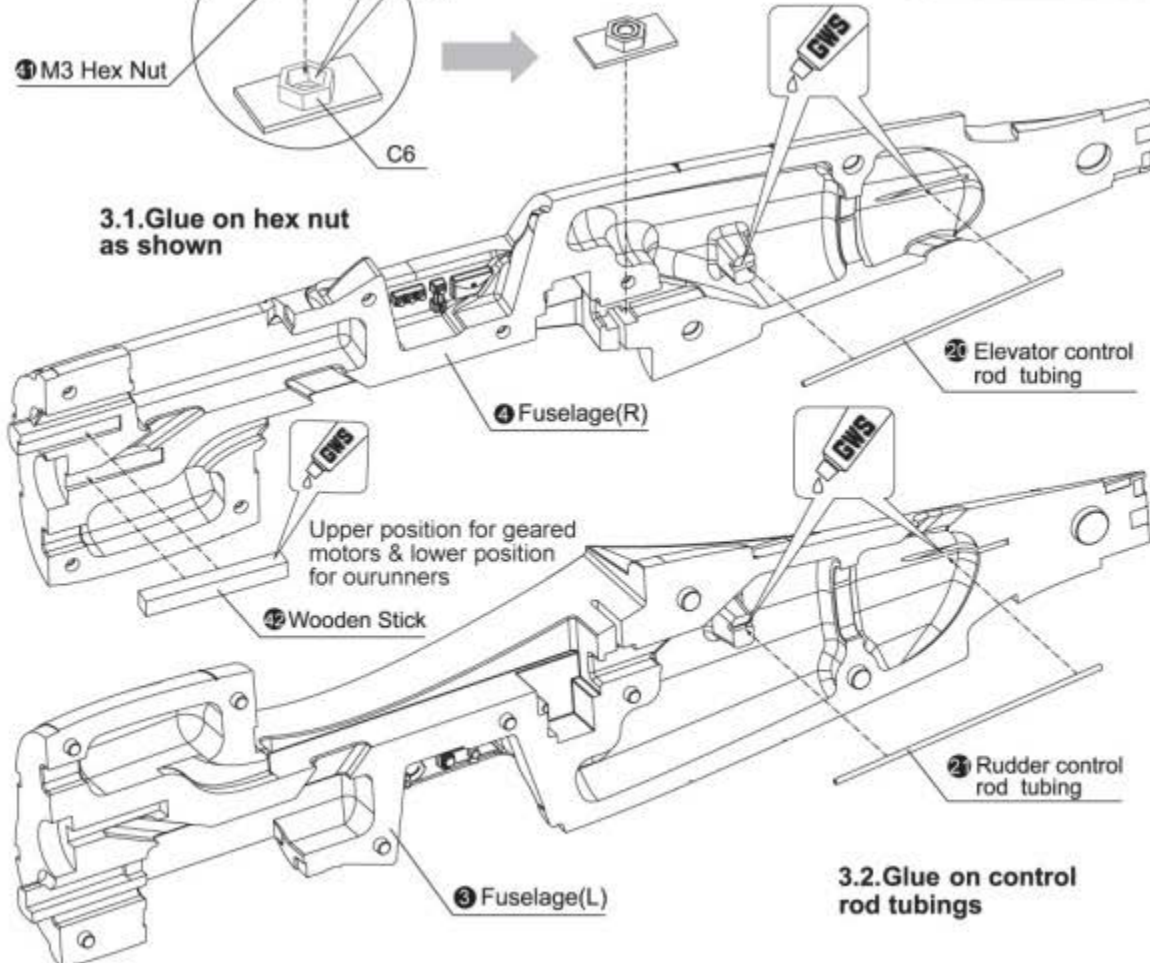

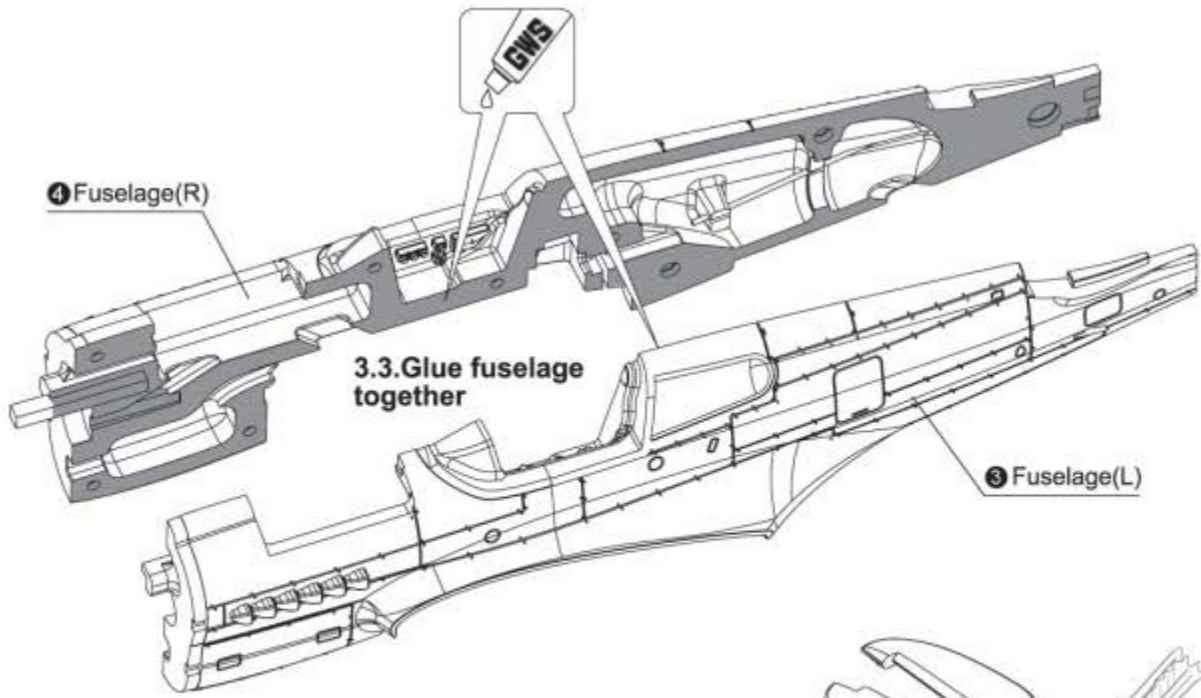

4. Stabilizer Assembly

16 Stabilizer Fiberglass Rod
3*1.6*300mm

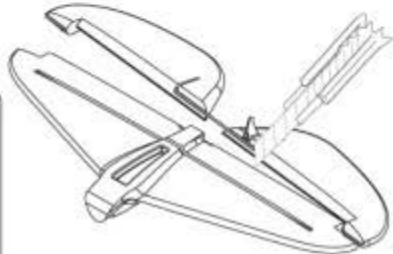
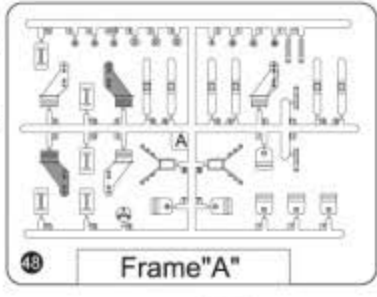

4.1. Glue on fiberglass Rod

19 Elevator Stiffener
1.6*100*25mm

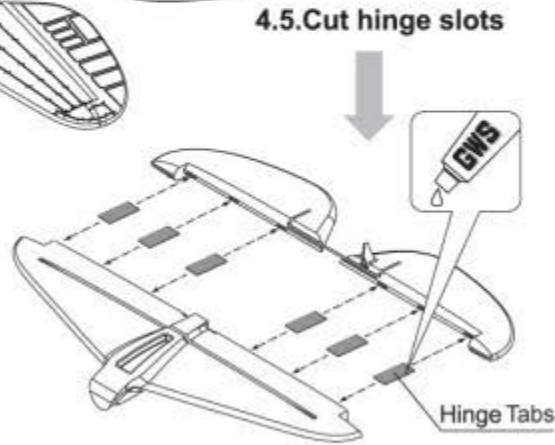
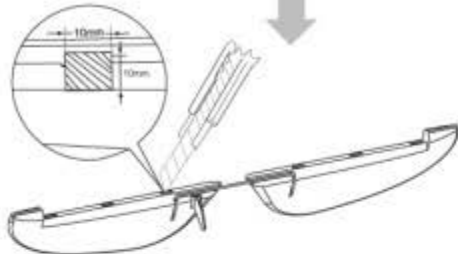
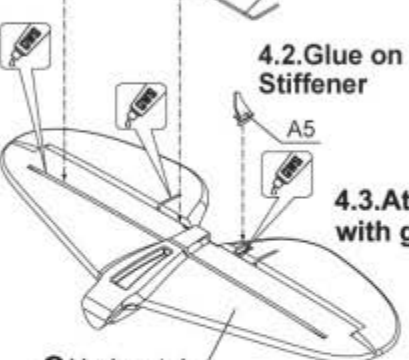

En

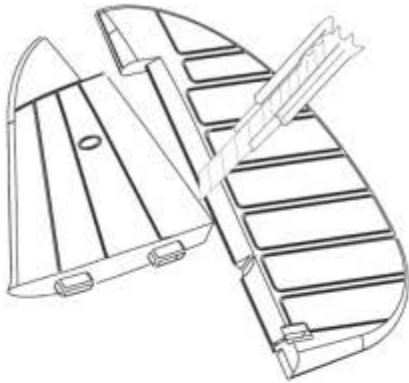

4.8. Cut rudder off as shown

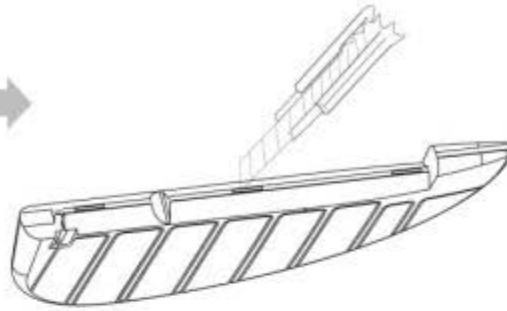

4.9. Cut hinge slots

4.10. Glue vertical stabilizer as shown

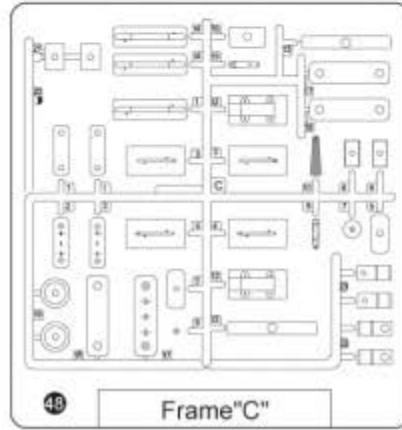
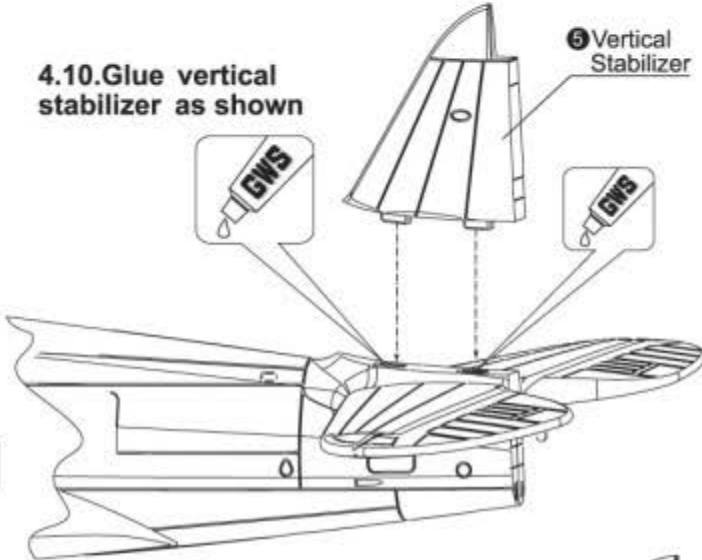

En

4.11. Glue on tail landing gear

4.12. Glue to vertical stabilizer as shown

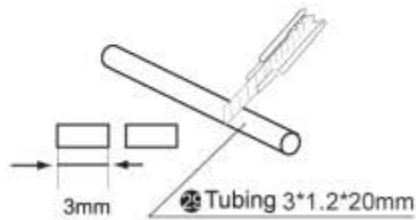
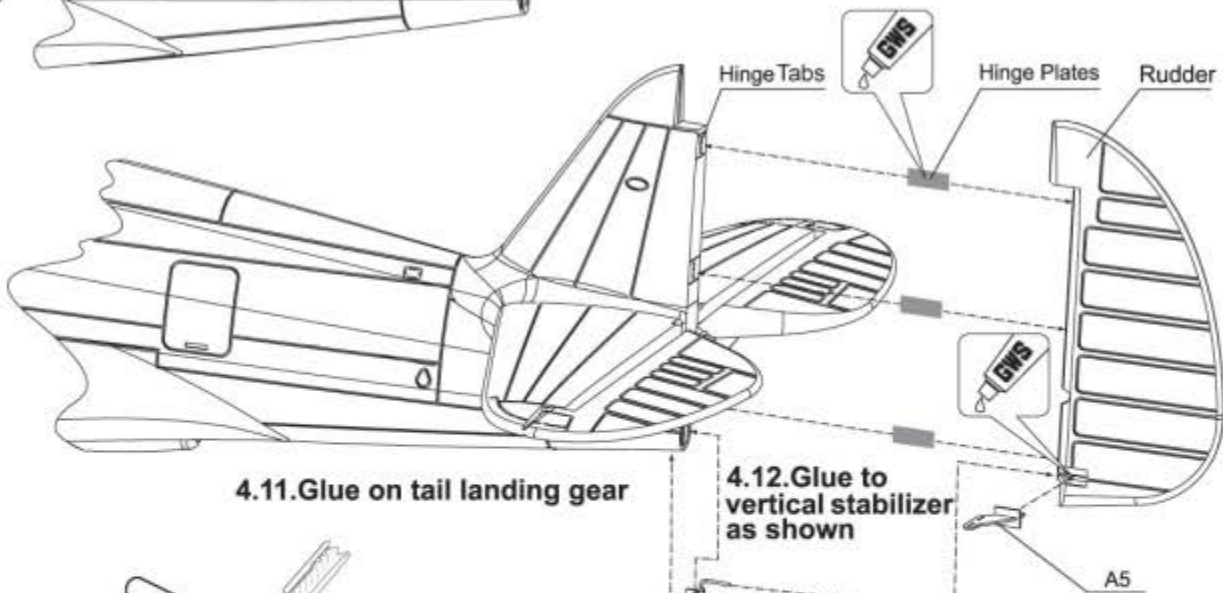

4.14. Cut tubing

4.15. Assemble tail landing gear



4.13. Attach horn with glue

5. Canopy Assembly

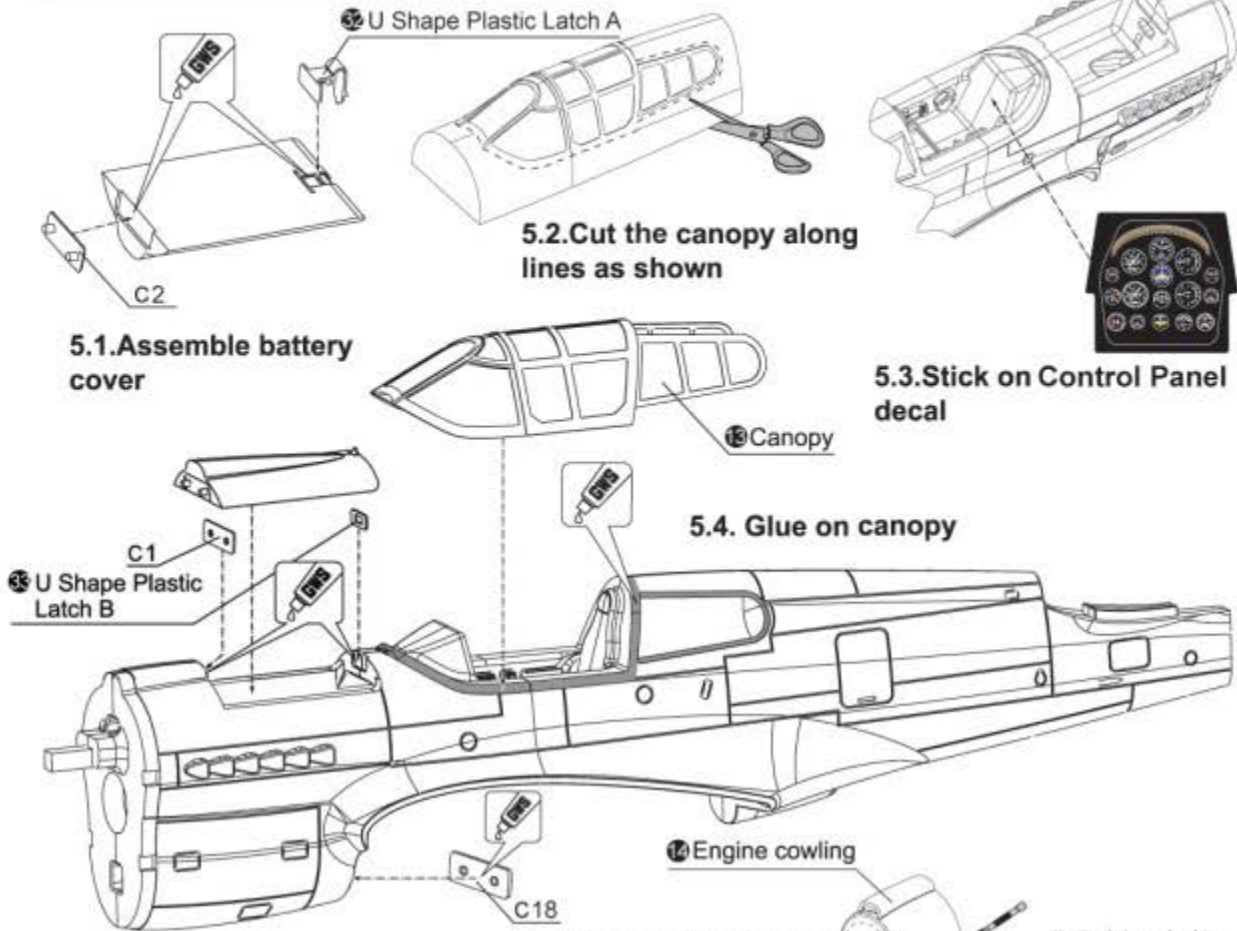

En

6. Power System Assembly

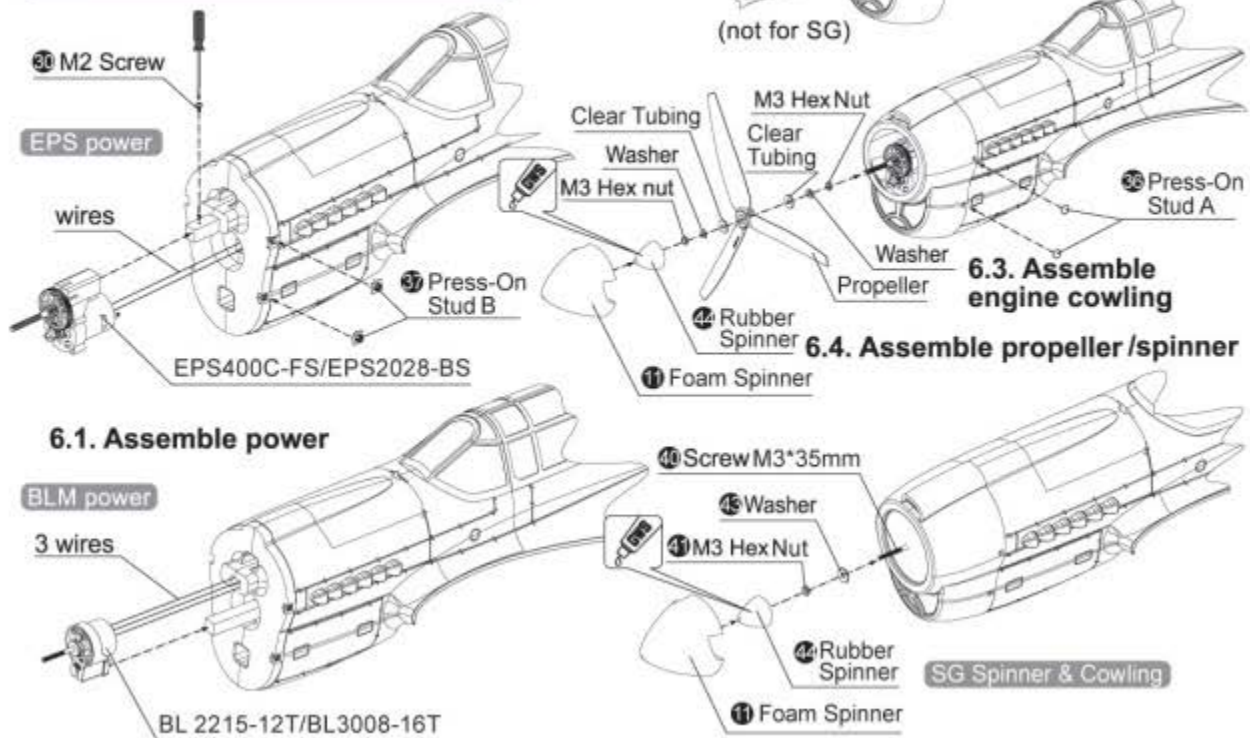

7. Control System Assembly

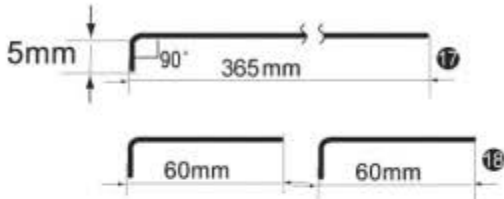

7.1. Bend control rods as shown

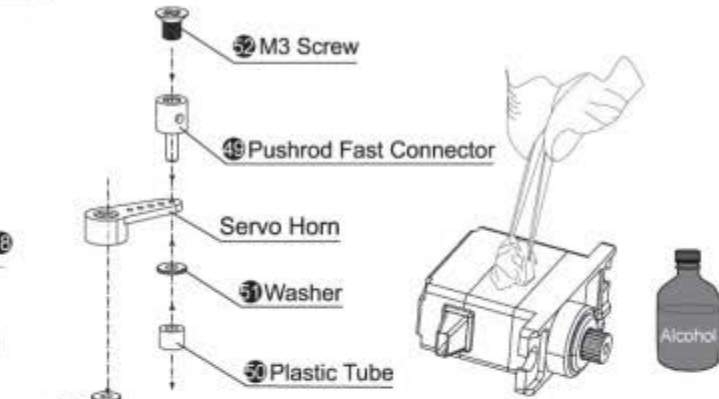

7.3. Clean the servo case as shown

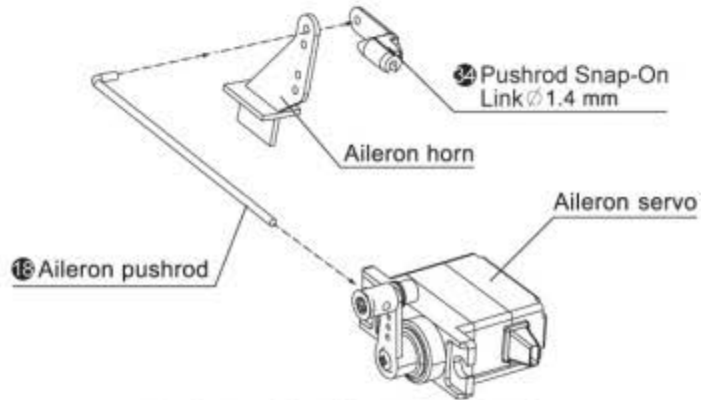

7.6. Assemble aileron pushrod

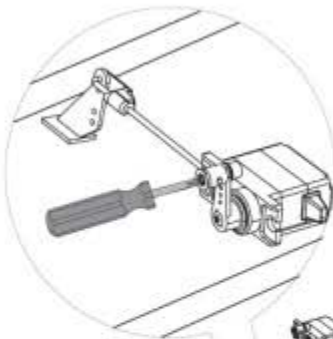

7.7. Secure Connector screws
(Be sure the servos and the ailerons are neutral)

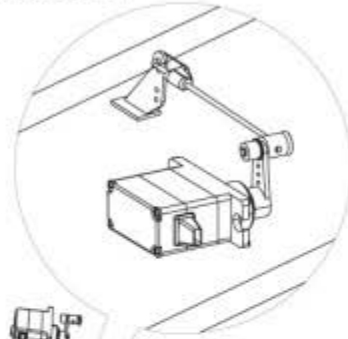

7.5. Bond aileron servos

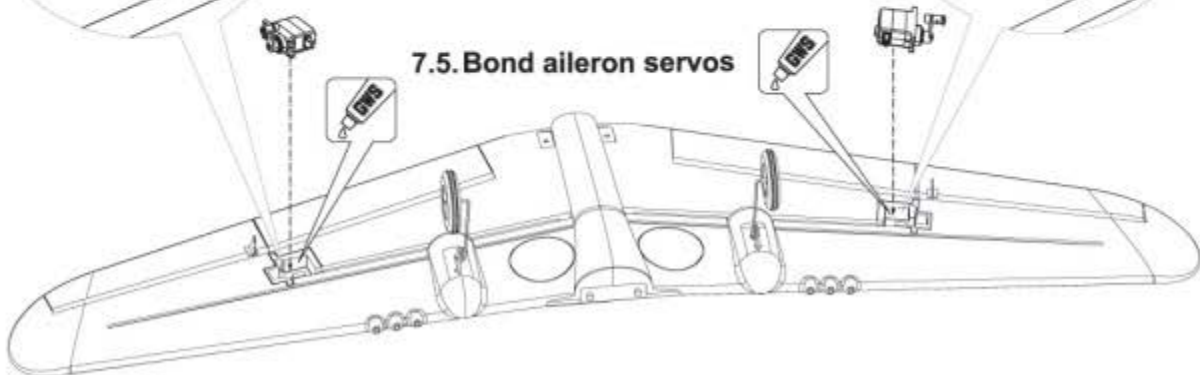

7.8. Battery Location

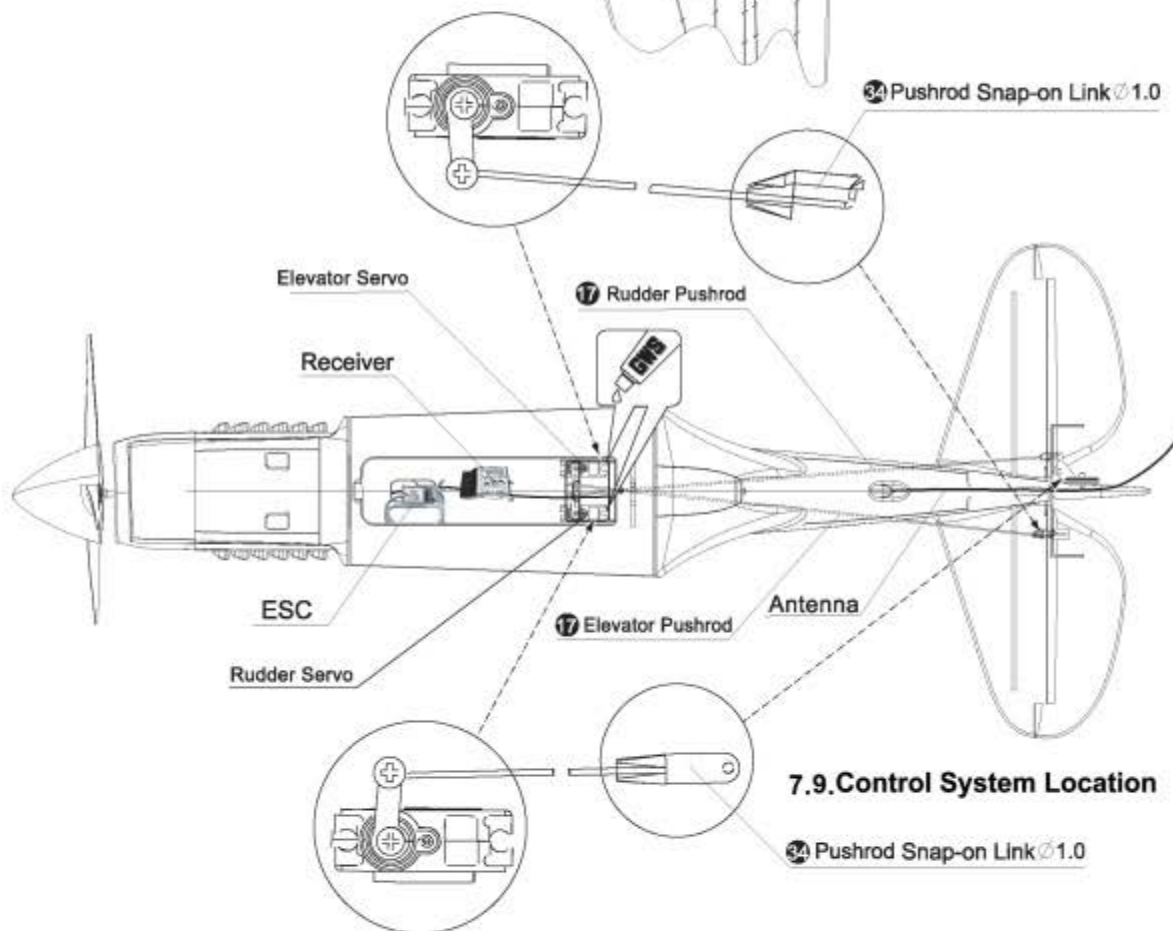
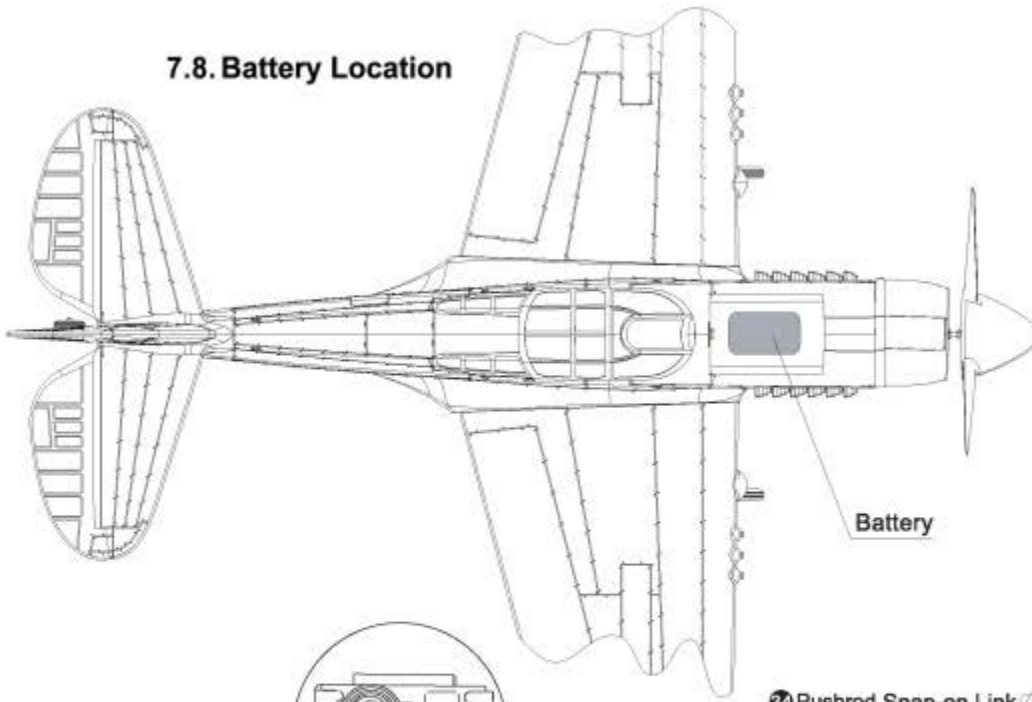

En

7.9. Control System Location

CAUTIONS BEFORE FLIGHT

1. Flying field should be wide-open and free of obstacles. Do not fly near power lines or buildings.
2. Flight must take place at approved sites. Do not fly in restricted air space.
3. Before each flight, make certain that the radio frequency is open to avoid interference.
4. First time flyers, please seek assistance from experienced flyers.
5. Always choose a flat smooth surface for rolling take-offs.

8. Control Throw & C.G.

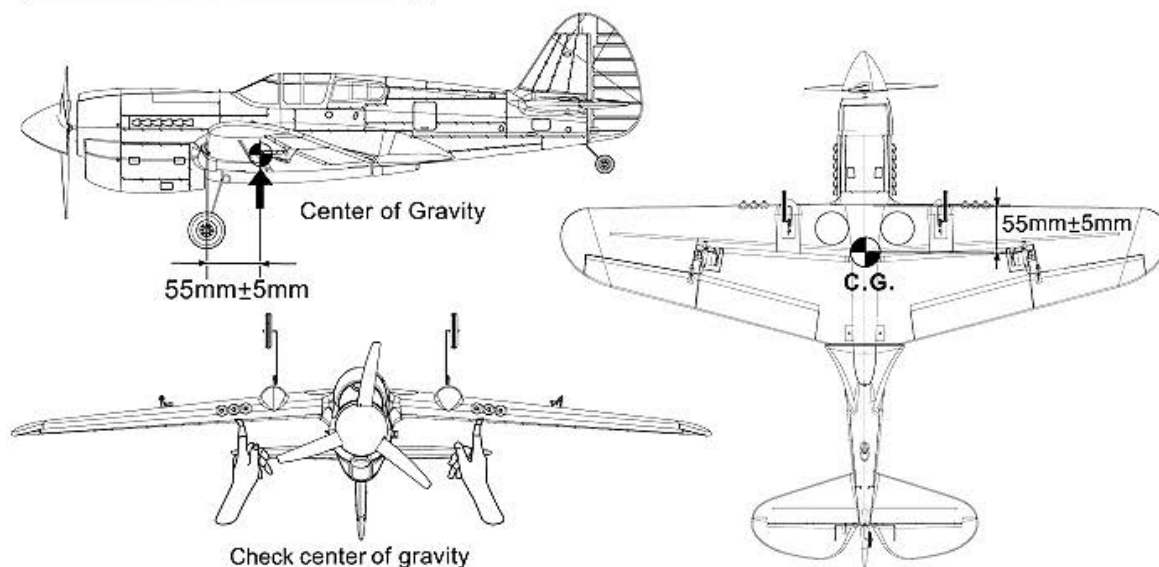

Control throws

Measured at the widest part of each control surface

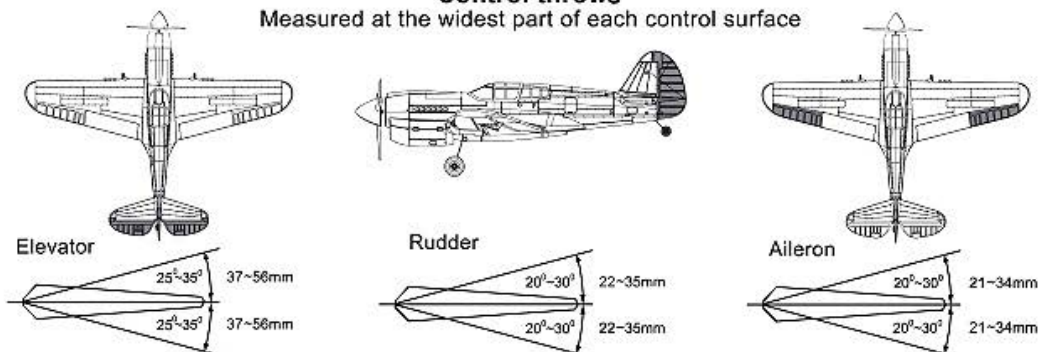

Control angle adjustment

To increase the throw
move linkage outward

To reduce the throw
move linkage outward

To reduce the throw
move linkage inward

To increase the throw
move linkage inward

Waterslide Decal Instruction

Tools Required: Sharp Scissors/Small Soft Paint Brush/Tweezers

- 1) Be sure the area to receive the waterslide decal is clean and free of oils.
- 2) Cut out the area around the edge of the decal image. Do not soak the whole decal sheet.
- 3) Soak the decal with clean water for 30-60 seconds.
- 4) Remove the decal from the water with tweezers when the decal is ready to slide. Position and place it (face up) on to the application surface.
- 5) Smooth out decal using a soft brush.
- 6) Carefully remove the backing paper from decal leaving the image on the application surface. Do not touch the decal image by fingers.

10.RC System & Wiring

EPS 400-FS Power System

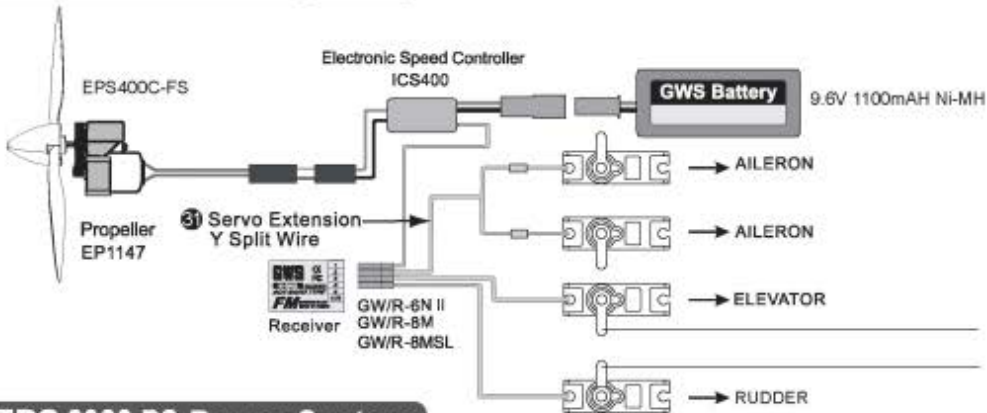

EPS 2028-BS Power System

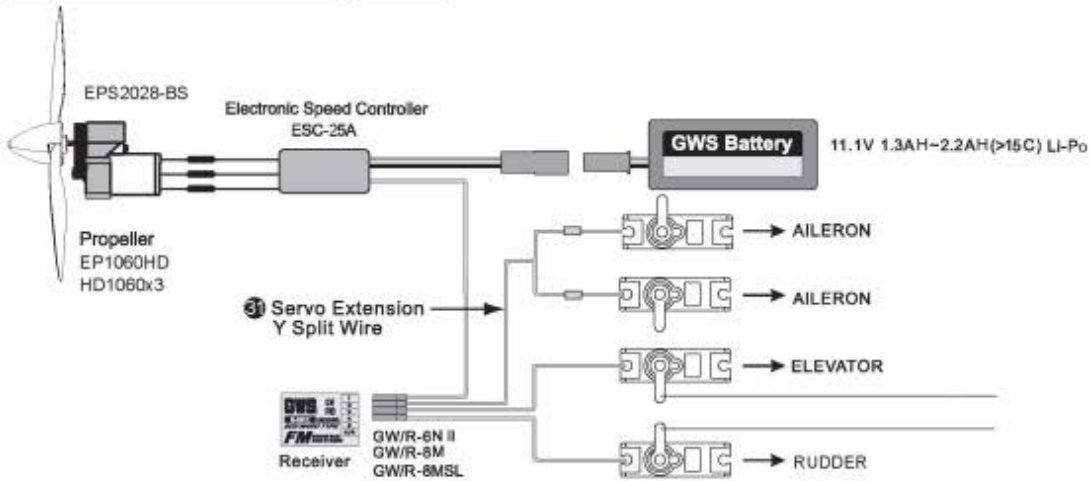

BLM Power System

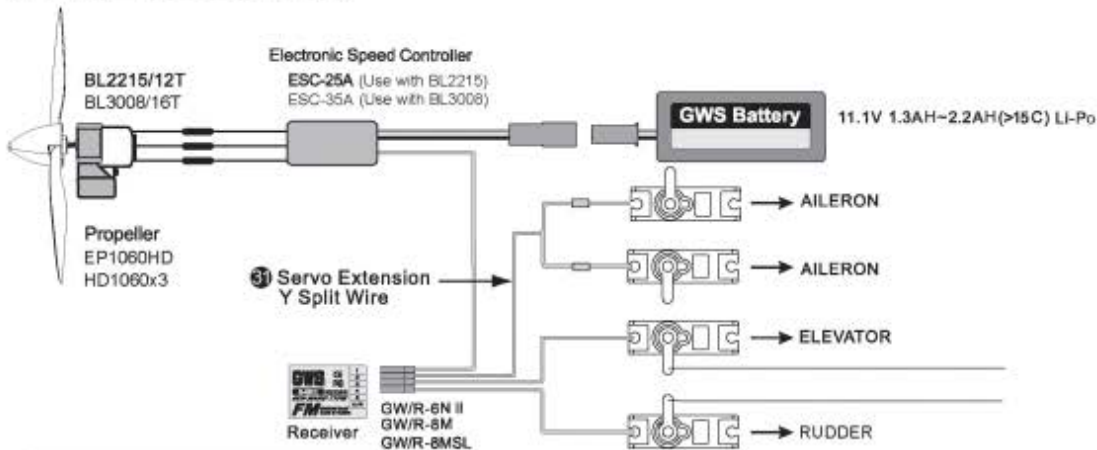

Receiver System Option

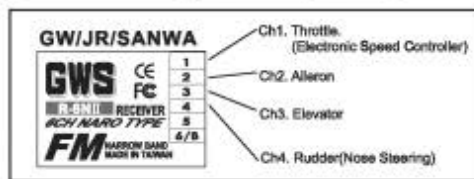

Channel Assignment for GWS/JR/SANWA

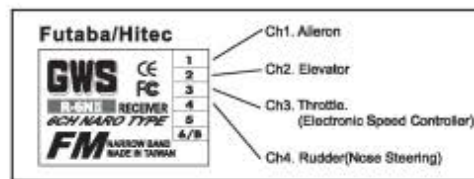

Channel Assignment for FUTABA/HITEC

En

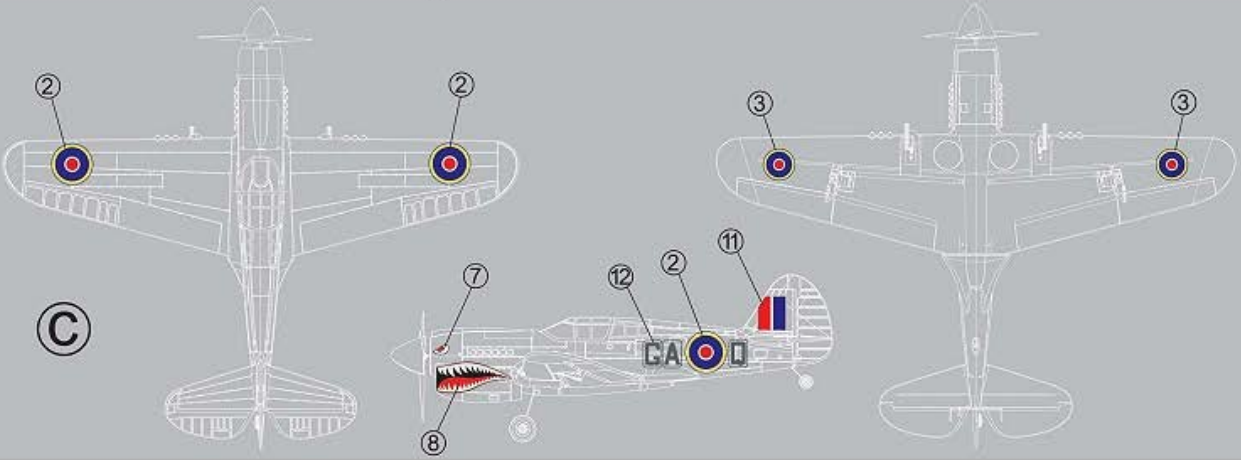
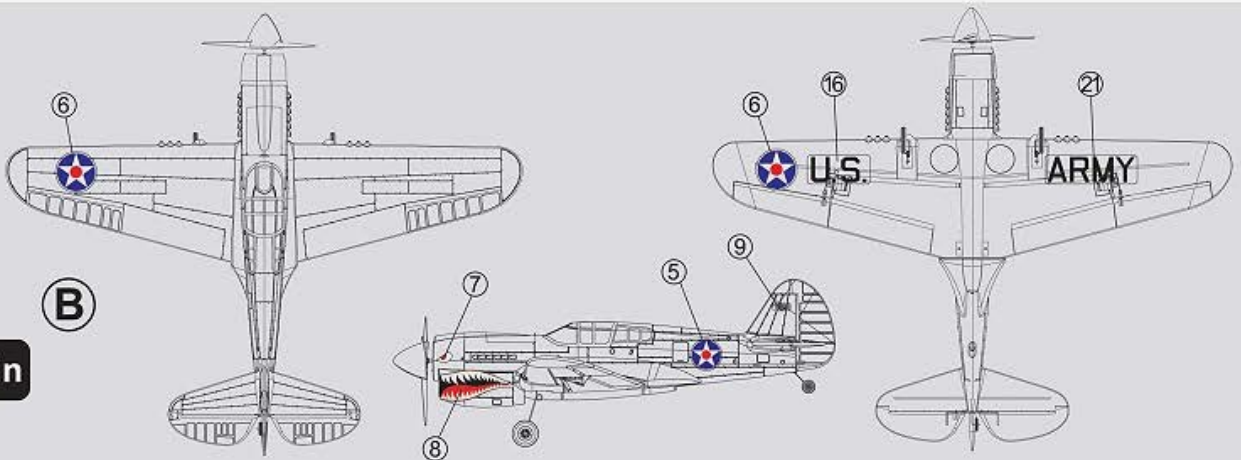
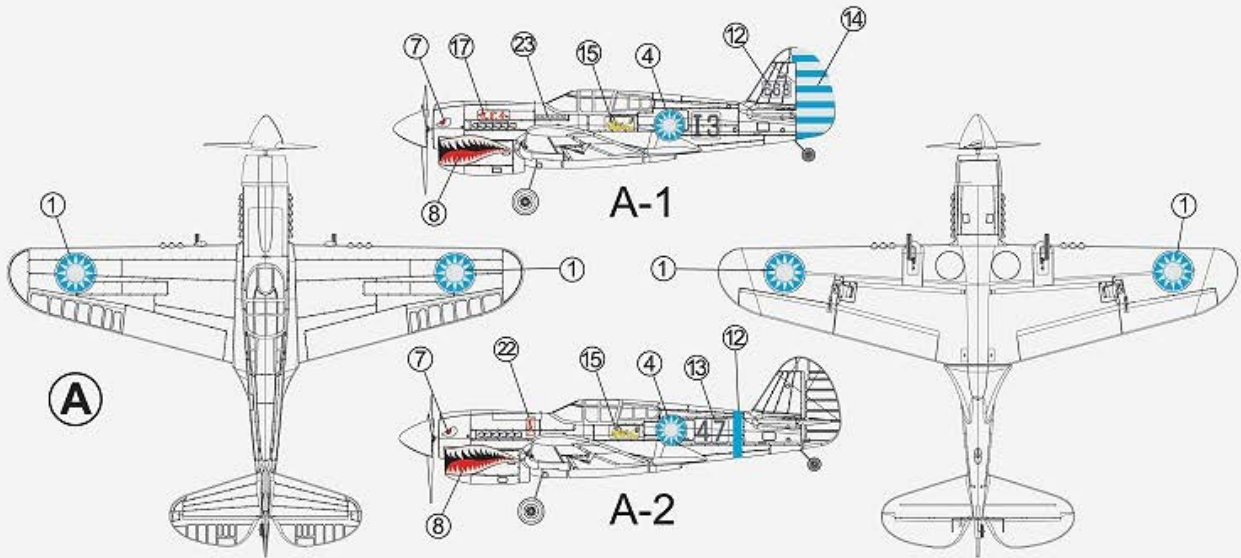

En

53 GWS40 Decal

